

**HAFCO WOODMASTER**

# WOOD LATHE OPERATION MANUAL



**Model No.**  
**WL-14V**  
Order Code W385

*Edition No* : SWL-002

*Date of Issue* : 05/2019

[www.machineryhouse.com.au](http://www.machineryhouse.com.au)



# OPERATION MANUAL

## MACHINE DETAILS

<b>MACHINE</b>	WOOD LATHE
<b>MODEL NO.</b>	WL-14V
<b>SERIAL NO.</b>	
<b>DATE OF MANF.</b>	

Distributed by



[www.machineryhouse.com.au](http://www.machineryhouse.com.au)

[www.machineryhouse.co.nz](http://www.machineryhouse.co.nz)

**NOTE:**

This manual is only for your reference. Owing to the continuous improvement of the machine, changes may be made at any time without obligation or notice. Please ensure the local voltage is the same as listed on the specification plate before operating this electric machine.



**NOTE:**

In order to see the type and model of the machine, please see the specification plate. Usually found on the back of the machine. See example (Fig.1)

**HAFCO**  
PRODUCT SPECIFICATION

MODEL:

CAPACITY:

SER. NO:

MFG DATE:

WEIGHT:

VOLTS:

MOTOR Kw:

[www.machineryhouse.com.au](http://www.machineryhouse.com.au)  
Made in China

Fig.1



## OPERATION MANUAL

### CONTENTS:

SPECIFICATIONS.....	4
FEATURES.....	5
SAFE WORK PROCEDURE.....	6
Before Operating Safety Checks.....	6
Operating Safety Checks.....	6
After Operations And Clean Up.....	6
Potential Hazards And Injuries.....	7
Don't.....	7
SAFETY PRECAUTIONS.....	7
ASSEMBLING THE WL-14V.....	8
Assembling the Tailstock.....	8
Adding The Accessory Tray.....	9
Adding a Bed Extension:.....	9
Connecting To The Power Source.....	10
OPERATING INSTRUCTIONS.....	10
Belt And Variable Speed Range.....	10
Controls.....	11
Spindle Start And Stop Button.....	11
Changing Forward And Reverse.....	11
Changing Speeds.....	12
Changing Belt Positions.....	12
Headstock Controls.....	13
Using the spindle index.....	13
Mounting a Faceplate or Chuck.....	13
Tool Rest.....	14
Tailstock.....	14
MAINTENANCE.....	15
Schedule.....	15
Cleaning.....	15
Belt Replacing and Tensioning Procedure.....	16
Troubleshooting.....	17
SPARE PARTS.....	18
RISK ASSESSMENT.....	22



## OPERATION MANUAL

### SPECIFICATIONS

#### Product Dimensions:

Weight.....	43 kg
Width (side-to-side) x Depth (front-to-back) x Height.....	852 x 270 x 442 mm
Footprint (Length x Width).....	825 x 216 mm

#### Main Specifications:

Swing Over Bed.....	356 mm
Swing Over Tool Rest Base.....	286 mm
Distance Between Centers.....	470 mm
Max. Distance Tool Rest to Spindle Center.....	204 mm
No of Spindle Speeds.....	Variable
Spindle Speed Range (2 Steps).....	450 – 1800 & 900 - 3850 RPM

#### Electrical:

Power Requirement.....	240V, Single-Phase, 50 Hz
Full-Load Current Rating.....	6A
Minimum Circuit Size.....	10A
Switch Type.....	Electromagnetic Switch

#### Motors:

Type.....	Universal Brush-Type
Power.....	3/4 HP/550W
Phase.....	Single-Phase
Amps.....	6A
Speed.....	1400 RPM
Power Transfer .....	Belt Drive
Bearings.....	Shielded & Permanently Lubricated

#### Spindle Information:

Spindle Taper.....	MT#2
Spindle Thread Size.....	M30 x 3.5 Pitch
Spindle Thread Direction.....	Right Hand
Spindle Bore.....	10.3 mm
Type of Included Spindle Center.....	Spur

#### Tool Rest Information:

Tool Rest Width.....	150 & 300 mm
Tool Rest Post Diameter.....	25.4 mm
Tool Rest Post Length.....	82.5mm

#### Tailstock Information

Tailstock Taper.....	MT#2
----------------------	------

## FEATURES

### Solid Construction

Well proven design. The critical components of the WL-14V Variable Wood Lathe are made from cast-iron for strength, rigidity and vibration reduction.

### Speed Range

The WL-14V Variable Wood Lathe is fitted with a 2-step Electronic Variable Speed motor with a low range for slower speeds from 450 RPM up to 1800 RPM.

The high range covers speeds from 900 RPM up to 3850 RPM for miniature turning work.

Electronic Variable Speed allows for quick dial-in of the correct speed for the job, material and conditions..

### Reverse Option

The WL-14V Variable Wood Lathe has the capability, at the flick of a switch, to change direction from forward to reverse. This feature enables the turner to sand with the lathe in reverse, eliminating problem areas which cannot normally be sanded smooth in the forward direction.

### Add-On Bed Extension System

An optional 650mm bed extension can be added to the bed to expand the length. (Order Code W385X)

### Lathe Stand

Optional machine stands can be added to the lathe to raise the machine to a working height. Two options are available. 1. For the lathe alone or 2. With the bed extension.



(Order Code W379)



(Order Code W379X)

**OPERATION MANUAL**

---

**SAFE WORK PROCEDURE**

**DO NOT use this machine unless you have read the instructions and understand the safe use and operation of the machine**



Dust masks must be worn at all times in work areas



Sturdy footwear should be worn at all times in work areas.



Safety glasses must be worn at all times in work areas. Hearing protection may be required.



Disconnect the machine from the power before any adjustments or servicing is commenced



Long and loose hair must be contained. Close fitting/protective clothing must be worn



Read and understand the manual before operating. Keep the manual in a safe place for future reference

**BEFORE OPERATING SAFETY CHECKS**

- Locate and ensure you are familiar with all machine operations and controls.
- Ensure all guards are fitted, secure and functional. Do not operate if guards are missing or faulty.
- Check workspaces and walkways to ensure no slip/trip hazards are present.
- Ensure the workpiece has been suitably prepared for the lathe operation.
- Workpiece must be securely fastened to face plate, chuck or between centres.
- Adjust speed to suit the diameter of the work and turning operation.
- Rotate the workpiece by hand to check clearance between tool rest and bed.
- Ensure the cutting tools are sharp and in good condition.
- Start the dust extraction unit before using the machine.

**OPERATING SAFETY CHECKS**

- Only one person may operate this machine at any one time.
- Before making adjustments, switch off and bring the machine to a complete standstill.
- Keep the tool rest adjusted close to the work and at the correct height.
- Adjust speed to suit the diameter of the work and turning operation.
- Stop the lathe and remove all tool rests before sanding.

**AFTER OPERATIONS AND CLEAN UP**

- Switch off the machine when work completed.
- Return all chisels and other tools to their rightful place
- Clean and cover the tool rests with a light oil
- Leave the machine in a safe, clean and tidy state.

**OPERATION MANUAL****SAFE WORK PROCEDURE Cont.****POTENTIAL HAZARDS AND INJURIES**

- Eye injuries from flying debris or defective timber.
- Hair/clothing getting caught in moving machine parts.
- Airborne dust.

**DO NOT**

- Do not use faulty equipment. Immediately stop using the suspect equipment.
- Never leave the machine running unattended.

**SAFETY PRECAUTIONS**

- Keep the tool on the tool rest. Tools should remain on the tool rest whenever the tool is engaged in the work piece.
- Remove the tool rest when sanding or polishing so fingers do not get pinched.
- Direction of feed. Feed work into blade or cutter only against the direction of rotation of work piece.
- Use the correct lathe tools. Do not use spindle turning chisels for faceplate mounted work or vice versa. Spindle turning tools used for faceplate turning may grab the work piece and pull the chisel from your control.
- When roughing be careful not to jam the lathe tool or chisel into work piece
- Do not use excessive force when attaching the work piece onto the headstock drive (spur) centre. Use a soft mallet.
- Do not use the tailstock to drive the work piece onto the drive (spur) centre when turning between centres. Secure with light pressure from the tailstock.
- When turning between centres, make sure the tailstock is locked before operating
- Never loosen the tailstock spindle or tailstock while work piece is turning.
- When faceplate turning, make sure work piece is securely fastened to the faceplate and that the appropriate size faceplate is used to support the work piece. Any screw fasteners must not interfere with the turning tool at the finished dimension of the work piece. Rough cut the work piece as close as possible to the finished shape before installing it on the faceplate.
- Do not operate the lathe if it is damaged or faulty. If any part(s) of the lathe is missing, damaged or broken, in any way, stop the lathe and disconnect it from the power supply. Replace missing, damaged, or failed parts before resuming the operation.
- The spindle threads are sharp and should not be used to lift the lathe, or to stop the rotation the spindle.



**Always use the correct tool for the job.  
DO NOT use the machine for operations  
it was not designed for**

**ASSEMBLING THE WL-14V VARIABLE WOOD LATHE:**

Part No.	Description	Qty.
1	WL-14V Wood Lathe	1
2	Heavy Duty Live Centre	1
3	Spur Centre	1
4	Draw Bar	1
5	Faceplate	1
6	150mm Tool Rest	1
7	Spanner	1
8	Hex Keys	4
9	Power Lead	1
10	300mm Tool Rest	1
11	Accessory Rack	1
12	M8 x 16mm Sck Hd Cap Screws	2

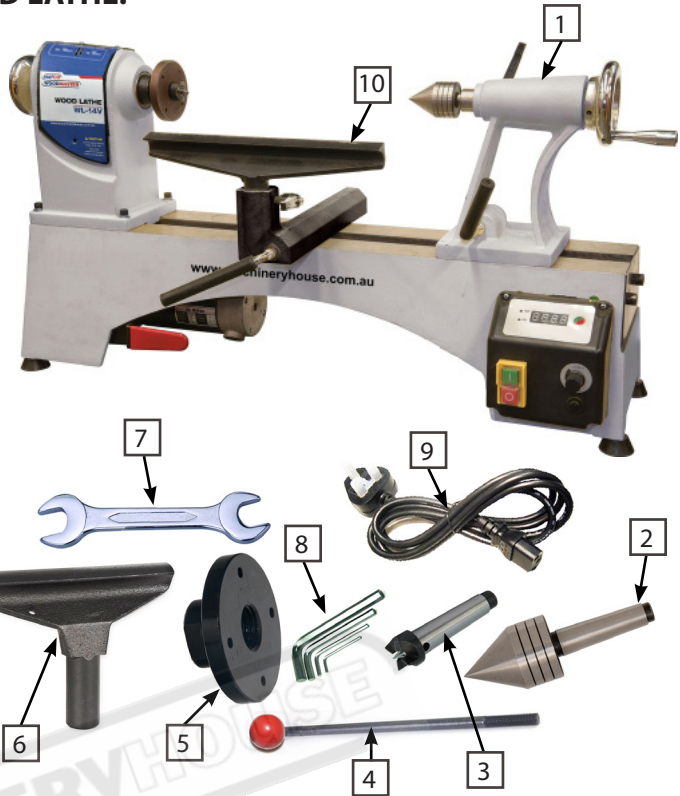

1. Unpack the lathe and its components from the shipping package.
2. Clean any parts coated with the rust preventative compound with a cloth moistened with a petroleum-based solvent or cleanser, such as Kerosene or Mineral Spirits. After all the parts have been cleaned, coat the lathe bed with dry silicon spray.
3. Insert the Tool Rest into the Tool Slide and secure it with the lock handle.
4. Assemble the Tailstock Handle and quill lock as below.
5. Place the Drive Spur Centre into the Headstock and the Live Centre into the Tailstock. Gently slide the tailstock up to the Headstock until the two points nearly touch. They should align. If not, consider loosening the bolts holding the headstock to the bed and aligning the headstock so the two centre points, align vertically and horizontally.
6. Screw the Hand wheel onto the outboard end of the Spindle.

**ASSEMBLING THE TAILSTOCK:**

1. Insert the wheel handle screw into the quill crank Handle.
2. Using a flat head screw driver, screw the quill crank handle onto the rear face of the quill adjusting wheel and tighten

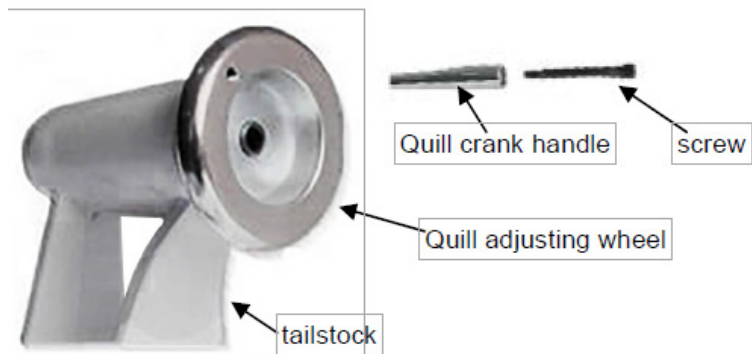

### ADDING THE ACCESSORY TRAY

The Lathe is supplied with an Accessory Tool Tray. This is fixed to the tailstock end of lathe bed after removing the existing bed end plate. Fix the tool tray with the two M8 x 16mm long cap screws supplied.

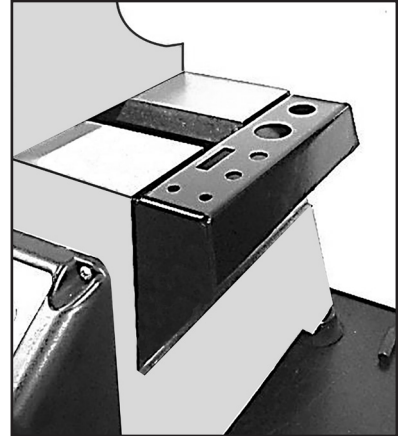

### ADDING A BED EXTENSION:

Each cast-iron Bed Extension adds 650mm to the lathe's length.

1. DISCONNECT THE MACHINE FROM THE POWER SUPPLY
2. Remove the accessory rack off the end of the lathe
3. File a small 45° chamfer on the top of the end of the lathe bed and on the top of the end of the bed extension.
4. If bench mounting, Fit the 2 rubber feet supplied to the extension base.
5. Carefully position the bed extension on the end of the lathe bed and fit the 2 off 10 x 25mm long cap screws with washers to join the 2 parts together.
- 6 To help align the 2 parts, before tightening the cap screws, position either the Tailstock, or the Tool Post Base, directly above the join in the 2 parts and lock it.
7. Tighten the 2 cap screws that hold the bed extension to the lathe.
8. Unlock the tailstock or tool post base and check join fit is level. Adjust if needed.
9. Reattach the accessory rack on the new end of the Lathe. This will stop tailstock being accidentally slid right off .

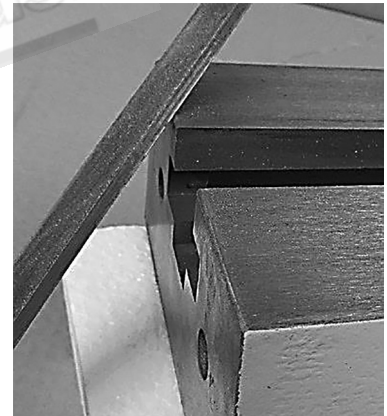

Chamfer Mating Parts



Accessory Rack

Tailstock used to align



## OPERATION MANUAL

---

### CONNECTING TO THE POWER SOURCE:

The electric motor, switch, cord and controllers are supplied with the WL-14V Wood Lathe. The plug must be plugged into a matching outlet that is properly installed and grounded in accordance with local electrical codes. The power cord should have 3-wires, with a grounding conductor and a grounding pin.

The machine is supplied with an Australian approved plug and lead appliance connector.

This gets connected to main electrical box socket, under bed at tailstock end of lathe as shown. Run the remainder of cord back under lathe to rear of the machine before plugging into 10 amp wall socket.

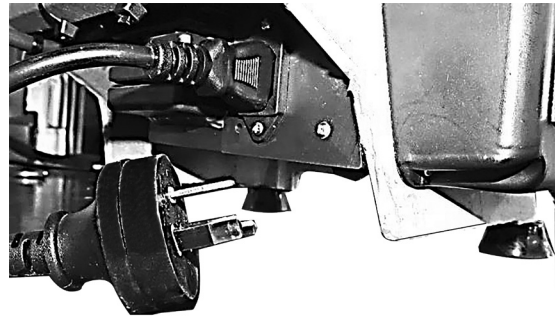

**⚠ WARNING** Improper connection of the motor can result in a risk of electrical shock. If it is necessary to use an extension cord, the cord should be grounded and be able to carry the correct amperage. Use a short cord length, to avoid power loss and over-heating.

### OPERATING INSTRUCTIONS

The DC motor contains brushes that contact the commutator. It is very important to allow between 30 to 45 minutes of 'run-in' time of these brushes before any turning or significant load is applied. This should be done in the higher rpm range. A clicking or swishing noise in the motor is normal which will reduce as the brushes wear in.

During normal operation, 5 minutes of warm-up may also be required on cold weather days. The motor is one of the most important elements in the lathe. The WL-14V Wood Lathe uses a high quality and powerful DC motor to provide the best turning performance. It has been pre-wired in such a way that it allows the lathe spindle to rotate in a counter-clockwise direction when facing the spindle.

This lathe uses a Permanent Magnet DC Motor (PMDC) which produces the most torque for conventional motors. The motor is nominally rated at 3/4 HP (550watts), however, it can produce a higher output.

### BELT AND VARIABLE SPEED RANGE:

Coupled with the high torque DC motor, is the use of a 2-step pulley to provide optimum power bands.

Speed Band	Type of Work	RPM Range
1	Slow speed: Large faceplate and spindle work.	450~1800
2	Fast speed: Small turning and miniature turning work.	900~3850

**NOTE:** To maximise spindle torque, use the low spindle speed range for spindle speeds of 1800RPM or less.

## HAFCO WOODMASTER

### OPERATION MANUAL

#### OPERATING INSTRUCTIONS Cont.

##### CONTROLS

**NOTE:** The machine uses electronic circuitry to control the speed and spindle direction. Because of this when you first turn on the power to the machine at the wall socket and because a spindle direction has not been chosen, the circuitry will prompt you of the direction with the flashing of the forward LED. To confirm the direction please give a quick press of the FWD/REV button. The FWD LED will then be illuminated and when the spindle start button is pressed the machine will start in a forward motion. The spindle will not start until the FWD/REV button has been pressed and a direction selected, displayed by a stationary LED.

Once the machine has been set this start procedure will not need to be repeated unless the power supply is turned off to the machine at the wall socket.

##### SPINDLE START AND STOP BUTTON

The start and stop buttons are situated on the front of the control panel. To start the machine press the start button and to stop press the stop button.

When the stop button is pressed the machine will come to a stop in approximately 4 seconds

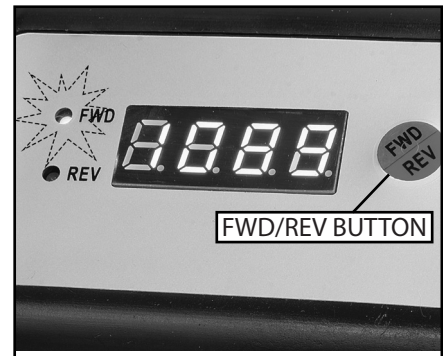

##### CHANGING FORWARD AND REVERSE

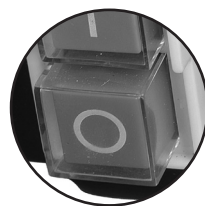

Ensure the machine has come to a complete stop before changing direction, only use the Start and stop button to start and stop the spindle. Then hold the FWD/REV button for 2 seconds and the opposite direction light will flash. Press the FWD/REV button again to confirm the direction and the light will stop flashing and remain on.

The direction of the spindle is then highlighted by the illumination of the FWD or REV LED on the top of the control box.

**OPERATION MANUAL**

---

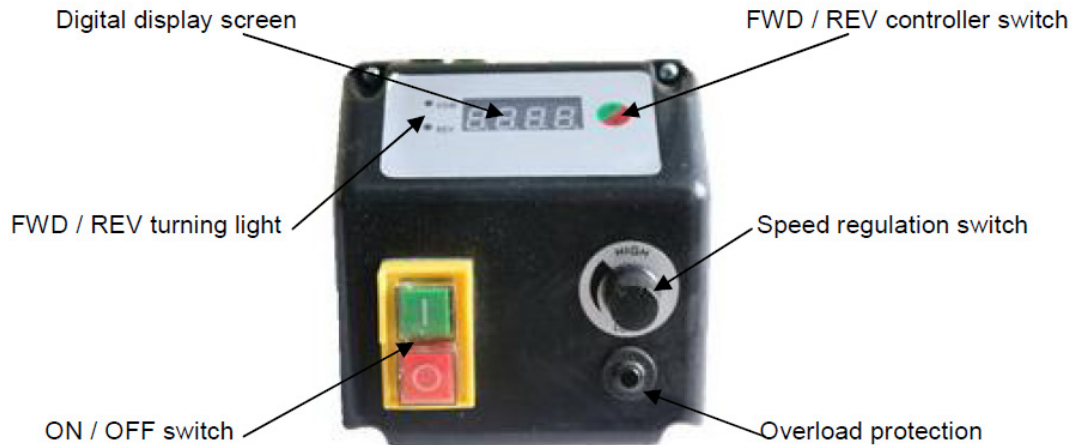
**OPERATING INSTRUCTIONS Cont.**

The speed range is achieved with a Variable Speed Controller. A micro-processor chip, in conjunction with other electronic components, allows the input power to be manipulated. In return, smooth Variable DC power can be delivered from the controller to the motor.

**CHANGING SPEEDS:**

1. When starting, set the Variable Speed Knob to about  $\frac{1}{4}$  of the speed range and slowly increase the speed to the desired RPM.
2. Starting the motor at the lowest possible setting may cause it to fail due to loading. However, the lowest setting can be achieved by reducing the RPM once the motor is in motion.
3. Rapid RPM changes from low up to high speed are not recommended.

**CHANGING BELT POSITIONS:**

1. To change the belt position, ensure the machine is switched "Off" and unplugged.
2. Unlock the headstock guard by the guard lock. Then lift the front of the guard upward.
3. Free the motor by loosening the motor lock handle.
4. Lift the motor plate handle slightly to get the belt off of the pulley. The motor adjustment range is 20mm.
5. Install the belt on the desired step, top and bottom.
6. Tension the belt by pressing down on the motor mount handle. Slightly higher pressure may be required for larger work.

**Caution:** Too much pressure on the motor pulley could damage the motor bearings, or break the belt.

7. When the correct tension has been made and while holding the motor at the correct tension, tighten the motor lock handle.

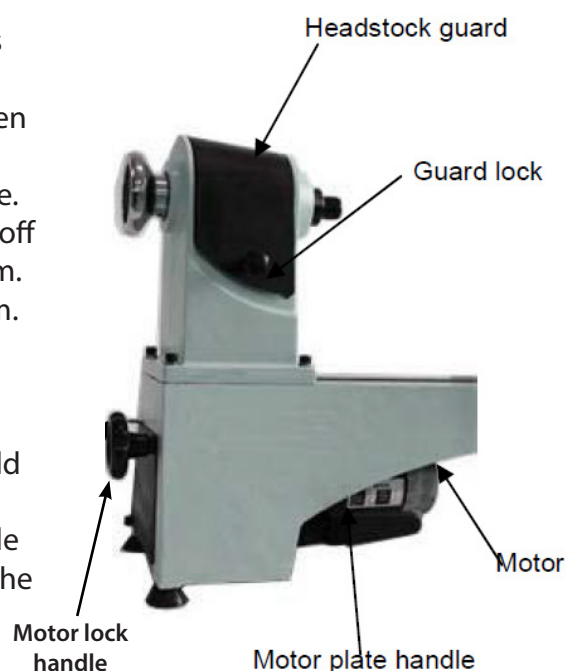

### HEADSTOCK CONTROLS:

The headstock houses the motor pulley, headstock pulley, bearings, a belt and the spindle. The headstock spindle accepts the centres and accessories with a No. 2 Morse taper. The thread size or pitch is M30 x 3.5 Pitch, RH.

### USING THE SPINDLE INDEX:

The spindle index lock is located on the back of the Headstock. This locking system works by inserting a pin into one of 12 notches, 30 degrees apart, in the plastic pulley attached to the spindle.

**Warning!** Make sure the index pin is out before operating the lathe. The index pin should be lifted into the unlocked indentation in the knob to prevent it from engaging while the spindle is turning.

### To lock the spindle:

1. Turn "Off" the lathe and wait for the spindle to stop.
2. Pull the index knob and turn it until the "LOCK" is upright and the pin drops into the hole. To lock the spindle, the pin must engage into a notch in the spindle pulley.

### To unlock the spindle:

1. Pull the index knob and turn it until the "UNLOCK" is upright.
2. Check to verify that the spindle can rotate freely and that the Index Knob has dropped into unlocked indentation to prevent it from engaging while the spindle is turning.

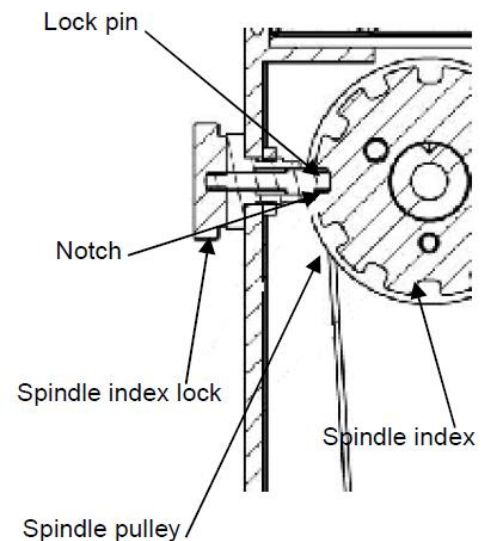

### MOUNTING A FACEPLATE OR CHUCK:

1. Disconnect the machine from the power supply.

**NOTE:** DO NOT use the spindle index lock to hold the headstock spindle in position when mounting the chuck or faceplate.

2. Use an allen key to release the safety screw on the side of the faceplate or chuck before installing or removing them.
3. Use the spanners supplied on the flats on the spindle and on the back of the chuck to loosen or tighten the chuck to the spindle when the chuck/faceplate is mounted
4. Install the faceplate or chuck onto the spindle threads. A spindle washer may be used in between the faceplate or chuck to make removal easier.

**Warning!** The faceplate or chuck body must contact the shoulder on the spindle bearing.

4. Use an allen key to tighten up the safety screw on the side of the faceplate or chuck.

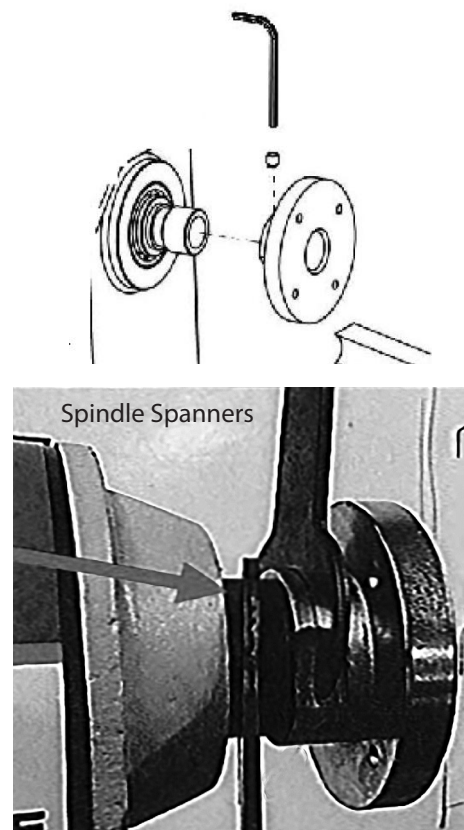

## TOOL REST

The tool's cutting edge should present to the wood at the proper angle without having to put yourself in an awkward position to accomplish that end. The cutting edge should be just above the centerline and as close as possible to the work piece without touching. It should be adjusted as the diameter reduces.

1. To move the Tool Slide along the bed, loosen the camshaft handle, move the tool slide to the desired position and tighten the cam shaft handle.
2. To adjust the Tool Rest, loosen the Tool Rest Lock Handle, position the Tool Rest, and tighten the Tool Rest Lock Handle.
3. Adjust the Tool Rest close to the work piece. Exact positioning may be varied to suit the turner. Before turning, rotate the stock, by hand, to make sure it clears the Tool Rest. At intervals, stop the lathe and readjust the Tool Rest.

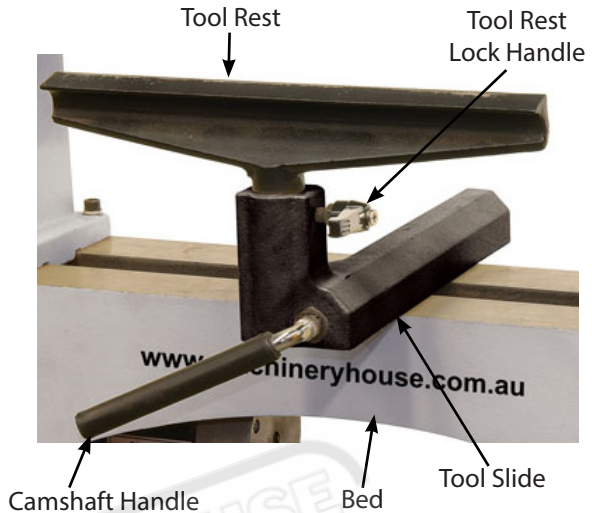

### Warning!

Lathe tools and chisels should remain on the Tool Rest whenever the tool is in contact with the work piece. Remove the Tool Rest when sanding or polishing so fingers do not get pinched.

## TAILSTOCK

1. To move the Tailstock along the bed, loosen the Tailstock Lock Arm, slide the Tailstock to the desired position, and tighten the Tailstock Lock Arm.
2. To move the Tailstock Quill in or out, loosen the Quill Lock and turn the Hand wheel clockwise or Counterclockwise. Lock the Quill in place with the Quill Lock.

**Warning!** Never loosen the tailstock Quill or tailstock while the work piece is turning.

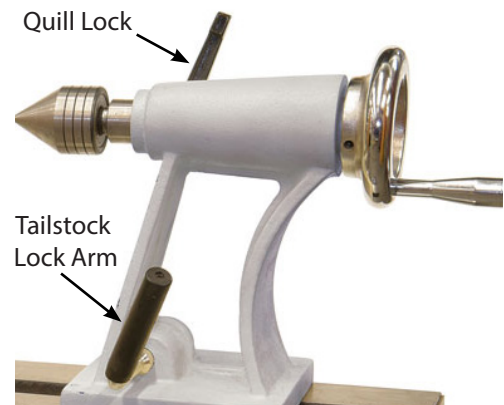

3. The tailstock Quill accepts centres and accessories with a No. 2 Morse Taper (#2 MT). To install a taper, use a quick, firm action by hand. Do not use excessive force.
4. To remove a taper, simply wind the quill into the Tailstock until the taper is ejected. Or insert the Knock Out Bar through the Tailstock Quill hole. While holding the taper so it doesn't fall, lightly tap it out.
5. The Tailstock Quill is hollow allowing you to bore holes through turnings while a hollow centre is used.

**OPERATION MANUAL****MAINTENANCE**

After each use, clean the work area and lathe. Vacuum scraps and dust from the inside of the headstock, between the lathe Bed, and under the tool slide and tailstock. Do not neglect this especially if the work piece was 'green' with excess moisture. Failure to clean-up after green turning can cause rust marks and pitting of the surfaces of the lathe.

If the tool slide becomes hard to move and adjust, cleaning and lubricating is required. If the tailstock quill becomes hard to use or the hand wheel is hard to turn, cleaning and lubricating is required.

Keep the motor free of saw dust and wood chips, especially around the fan housing. Periodically check for any abnormal noise or excessive heat. The motor brushes should be checked every five years and replaced when the brush length is less than 6mm.

**SCHEDULE**

For optimum performance from your machine, follow this maintenance schedule and refer to any specific instructions given in this section.

**Daily Check:**

- For loose mounting bolts.
- Worn or damaged wires.
- Worn switch
- For any other unsafe condition

**Monthly Check:**

- Belt tension, damage, or wear.
- Clean/vacuum dust buildup off of motor.

**CLEANING**

Cleaning the model WL-14V is relatively easy. Vacuum excess wood chips and sawdust, and wipe off the remaining dust with a dry cloth. If any resin has built up, use a resin dissolving cleaner to remove it. Treat all unpainted cast iron and steel with a non-staining lubricant after cleaning.

Protect the unpainted cast iron surfaces on the lathe by wiping them clean after every use, this ensures moisture from wood dust does not remain on bare metal surfaces.

**OPERATION MANUAL**
**BELT REPLACING AND TENSIONING PROCEDURE**

The drive belt stretches as the lathe is used. Most of the stretching will occur during the first 16 hours, but may continue with further use. If the lathe loses power while making a cut, the belt may be slipping and need tensioning. If the belt shows signs of excessive wear, or damage, replace it.



1. Disconnect the machine from the power.
2. Loosen screw (19#) and remove the handle wheel.
3. Loosen Motor locking handle and open side fender plate.
4. Release belt tension, then remove belt from motor pulley.
5. Remove the belt off the main pulley and feed the belt through the hole at the end of the machine.
6. Slide the new belt in through the hole in the end of the machine and slide it over the spindle pulley.
7. Place the new belt over the motor pulley.
8. Press belt tension lever down, then tighten Motor locking handle.
9. Press belt with moderate pressure in the centre to check tension.
10. Close the Fender Plate.

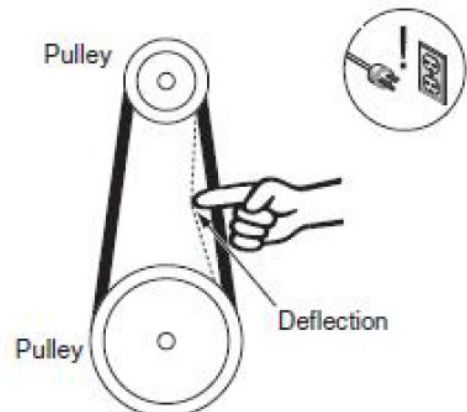
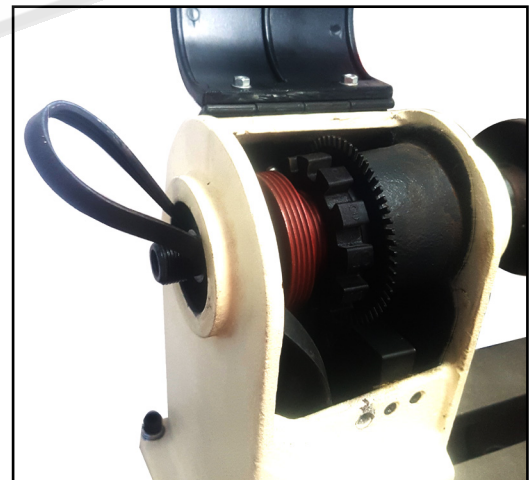

**NOTE:** The Belt is correctly tensioned when there is approximately 12mm deflection when pushed.



## OPERATION MANUAL

### TROUBLESHOOTING

Symptom	Possible Cause	Possible Solution
Machine does not start or a breaker trips.	<ol style="list-style-type: none"> <li>1. Plug/receptacle is at fault or wired incorrectly.</li> <li>2. Power supply is at fault/switched OFF.</li> <li>3. Motor on button or ON/OFF switch is at fault.</li> <li>4. Wiring is at fault.</li> <li>5. Motor is at fault.</li> </ol>	<ol style="list-style-type: none"> <li>1. Test for good contacts; correct the wiring.</li> <li>2. Ensure hot lines have correct voltage on all legs and main power supply is switched ON.</li> <li>3. Replace faulty on button or ON/OFF switch.</li> <li>4. Check for broken wires test and repair/replace as necessary.</li> <li>5. Test the motor and repair or replace.</li> </ol>
Machine stalls or is under powered.	<ol style="list-style-type: none"> <li>1. Plug/receptacle is at fault.</li> <li>2. Motor bearings are at fault.</li> <li>3. Motor has overheated.</li> <li>4. Motor is at fault.</li> </ol>	<ol style="list-style-type: none"> <li>1. Test for good contacts; correct the wiring.</li> <li>2. Test by rotating shaft; rotational grinding/loose shaft requires bearing replacement.</li> <li>3. Clean off motor, let cool, and reduce workload.</li> <li>4. Test/repair/replace.</li> </ol>
Machine has a vibration or noisy operation.	<ol style="list-style-type: none"> <li>1. Motor or component is loose.</li> <li>2. Motor fan is rubbing on fan cover.</li> <li>3. Workpiece or chuck is at fault.</li> <li>4. Motor bearings are at fault.</li> </ol>	<ol style="list-style-type: none"> <li>1. Inspect/replace damaged bolts/nuts, and re-tighten</li> <li>2. Replace dented fan cover; replace loose/damaged fan.</li> <li>3. Center workpiece in chuck or face plate; reduce rpm; replace defective chuck.</li> <li>4. Test by rotating shaft; rotational grinding/loose shaft requires bearing replacement.</li> </ol>
Vibration noise while machine is running or when speed is changed	<ol style="list-style-type: none"> <li>1. Belt cover loose.</li> <li>2. Belt cover bent or dented and is making contact with the motor pulley or belt.</li> </ol>	<ol style="list-style-type: none"> <li>1. Tighten the belt cover lock handle; if necessary</li> <li>2. Remove belt cover and inspect the inside for dents bends, or indications of rubbing. Tap out the dent with a rubber mallet, bend back into proper shape, or shim belt cover away from the motor pulley.</li> </ol>
Motor is running but spindle is not turning.	<ol style="list-style-type: none"> <li>1. Belt is loose, broken, or has come off the pulley.</li> <li>2. Belt broken</li> </ol>	<ol style="list-style-type: none"> <li>1. Inspect belt and tighten, reinstall, or replace if damaged.</li> <li>2. Replace the belt</li> </ol>
Chisels grab or dig into the workpiece.	<ol style="list-style-type: none"> <li>1. Tool rest set too low.</li> <li>2. Tool rest set too far from workpiece.</li> <li>3. Wrong chisel/tool being used.</li> <li>4. Chisel/tool dull.</li> </ol>	<ol style="list-style-type: none"> <li>1. Set tool rest higher.</li> <li>2. Move the tool rest closer to the workpiece.</li> <li>3. Use the correct tool; educate yourself by reading trade books or seek help from an experienced lathe operator.</li> </ol>
Bad surface finish.	<ol style="list-style-type: none"> <li>1. Wrong spindle speed.</li> <li>2. Dull chisel or wrong chisel being used for the operation.</li> </ol>	<ol style="list-style-type: none"> <li>1. Use trial-and-error to find a better spindle speed.</li> <li>2. Sharpen chisel or try a different chisel.</li> </ol>
Tailstock moves	<ol style="list-style-type: none"> <li>1. Tailstock mounting bolt loose.</li> <li>2. Too much clamping pressure applied by tailstock.</li> <li>3. Bed surface is oily or greasy.</li> </ol>	<ol style="list-style-type: none"> <li>1. Tighten.</li> <li>2. Apply less clamping pressure with tailstock.</li> <li>3. Clean bed surface to remove oil/grease.</li> </ol>
Can't remove tapered tool from tailstock barrel.	<ol style="list-style-type: none"> <li>1. Tailstock barrel had not retracted all the way back into the tailstock.</li> <li>2. Debris was not removed from taper before inserting into barrel.</li> </ol>	<ol style="list-style-type: none"> <li>1. Turn the barrel handwheel until it forces taper out of barrel.</li> <li>2. Always make sure that taper surfaces are clean.</li> </ol>

## SPARE PARTS SECTION

The following section covers the spare parts diagrams and lists that were current at the time this manual was originally printed. Due to continuous improvements of the machine, changes may be made at any time without notification.

### HOW TO ORDER SPARE PARTS

1. Have your machines model number, serial number & date of manufacture on hand, these can be found on the specification plate mounted on the machine
2. A scanned copy of your parts list/diagram with required spare part/s identified
3. Go to [www.machineryhouse.com.au/contactus](http://www.machineryhouse.com.au/contactus) and fill out the enquiry form attaching a copy of scanned parts list.



**SPARE PARTS**

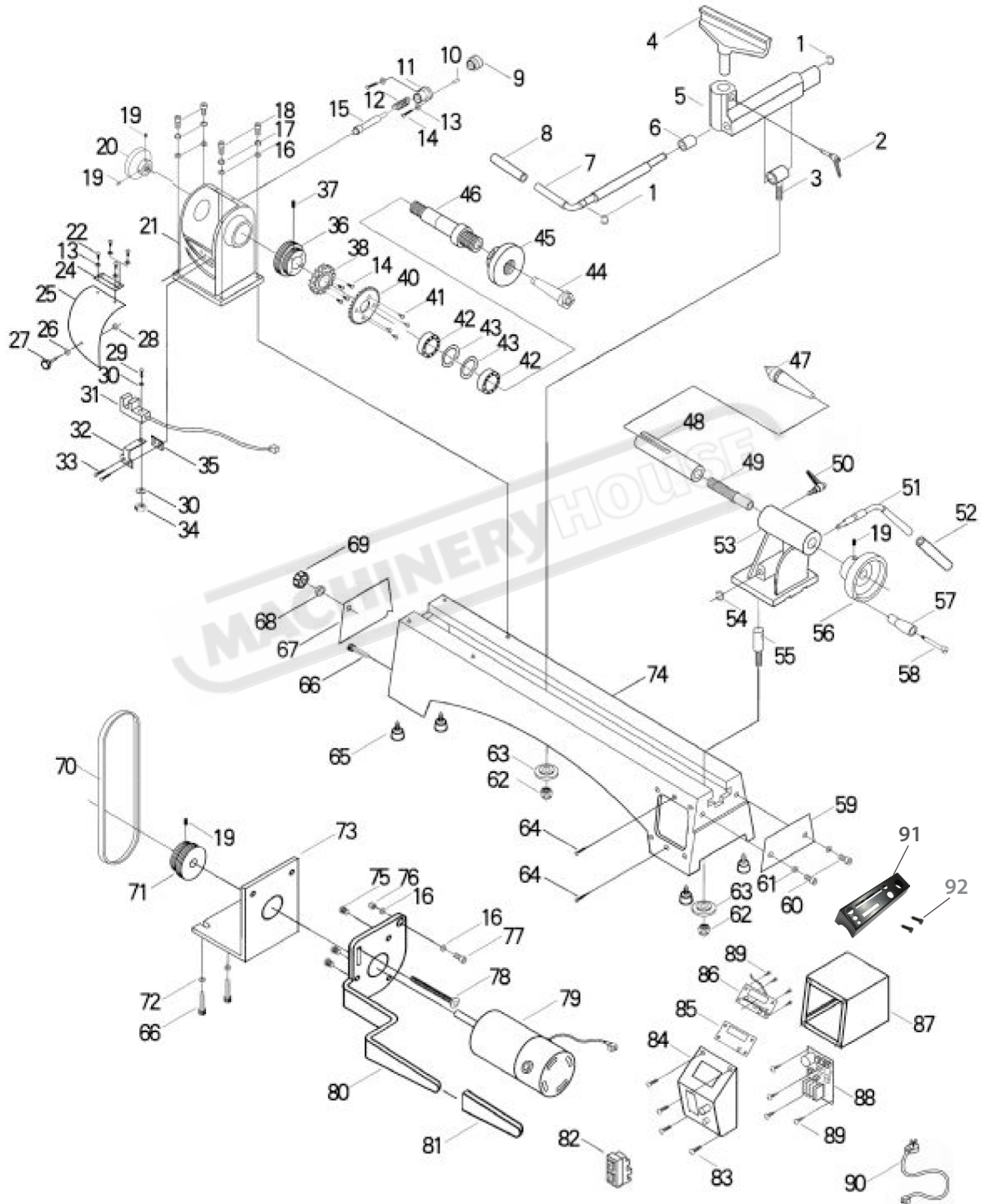

## OPERATION MANUAL

### SPARE PARTS Cont.

No.	Description	Qty	No.	Description	Qty
1	Retaining ring 12	2	40	Ring gear	1
2	Tool rest lock handle	1	41	Tap screw 4x10	4
3	Tool rest cam follower	1	42	Spindle bearing	2
4	300mm tool rest	1	43	Circlip 47	2
5	Toolslide	1	44	Spur centre	1
6	Tool rest bushing	1	45	Faceplate	1
7	Camshaft handle	1	46	Spindle	1
8	Handle sleeve	1	47	Live centre	1
9	Index pin knob	1	48	Tailstock quill	1
10	Tension pin 4x14	1	49	Tailstock leadscrew	1
11	Index pin housing	1	50	Lock handle	1
12	Spring	1	51	Tailstock lever	1
13	4mm Washer	6	52	Handle sleeve 2	1
14	Pan head screw M4x16	2	53	Tailstock	1
15	Index pin	1	54	Retaining ring 10	1
16	8mm washer	4	55	Cam follower tailstock	1
17	8mm spring washer	4	56	Quill adjusting wheel	1
18	Hex socket screw M8x30	4	57	Quill crank handle	1
19	Hex socket screw M6x12	3	58	Shoulder screw	1
20	Handle wheel	1	59	Retaining plate	1
21	Headstock	1	60	Hex socket screw M10x12	2
22	Pan head screw M4x12	4	61	10mm washer	2
24	Hinge	1	62	M10 locknut	2
25	Headstock guard	1	63	Lock plate	2
26	Washer	1	64	Tap screw 4x20	2
27	Headstock guard lock	1	65	Rubber foot	4
28	E ring 4	1	66	Hex socket screw M5x12	3
29	Pan head screw M3x12	1	67	Fender plate	1
30	3mm washer	2	68	Washer	1
31	Speed sensor	1	69	Motor locking handle	1
32	Insert plate	1	70	Belt	1
33	Sunk screw M4x10	2	71	Motor pulley	1
34	Nut M3	1	72	5mm washer	2
35	Plate	1	73	Fixed plate	1
36	Drive pulley	1	74	Main bed	1
37	Hex screw M6x12	1	75	Sunk screw M6x12	3
38	Spindle index wheel	1	76	M8 locknut	1

**OPERATION MANUAL**
**SPARE PARTS Cont.**

No.	Description	Qty	No.	Description	Qty
77	Hex socket screw M8x30	1	84	Control panel	1
78	Carriage bolt M8x120	1	85	Digital display	1
79	Motor	1	86	Display control board	1
80	Belt tension lever	1	87	Controller box	1
81	Motor plate handle sleeve	1	88	Controller board	1
82	Switch	1	89	Tap screw 3x10	8
83	Tap screw 4x24	4	90	Power cord	1
			91	Tool Accessory Rack	1
			92	M8x16mm Sck Hd Cap Scr	2

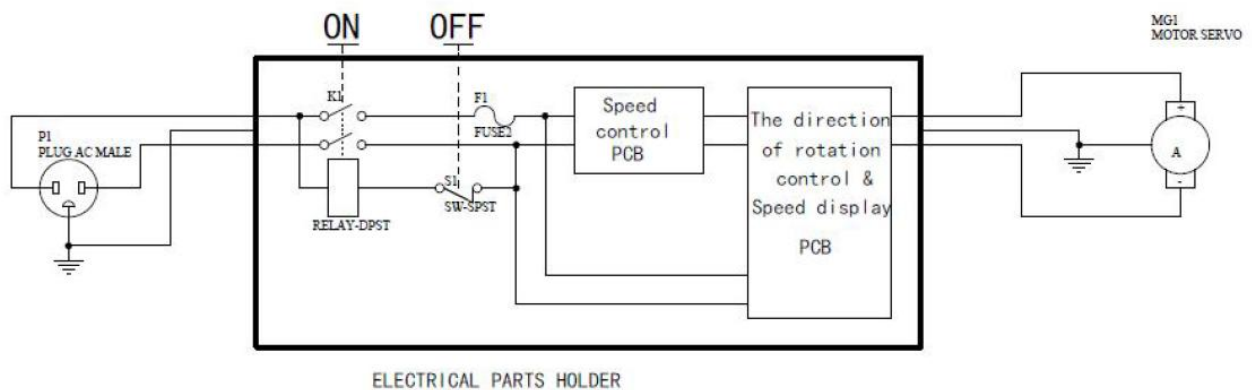
**Wiring Diagram**



# WARNING

## General Machinery Safety Instructions

---

Machinery House  
requires you to read this entire Manual before using this machine.

- 1. Read the entire Manual before starting machinery.** Machinery may cause serious injury if not correctly used.
- 2. Always use correct hearing protection when operating machinery.** Machinery noise may cause permanent hearing damage.
- 3. Machinery must never be used when tired, or under the influence of drugs or alcohol.** When running machinery you must be alert at all times.
- 4. Wear correct Clothing.** At all times remove all loose clothing, necklaces, rings, jewelry, etc. Long hair must be contained in a hair net. Non-slip protective footwear must be worn.
- 5. Always wear correct respirators around fumes or dust when operating machinery.** Machinery fumes & dust can cause serious respiratory illness. Dust extractors must be used where applicable.
- 6. Always wear correct safety glasses.** When machining you must use the correct eye protection to prevent injuring your eyes.
- 7. Keep work clean and make sure you have good lighting.** Cluttered and dark shadows may cause accidents.
- 8. Personnel must be properly trained or well supervised when operating machinery.** Make sure you have clear and safe understanding of the machine you are operating.
- 9. Keep children and visitors away.** Make sure children and visitors are at a safe distance for you work area.
- 10. Keep your workshop childproof.** Use padlocks, Turn off master power switches and remove start switch keys.
- 11. Never leave machine unattended.** Turn power off and wait till machine has come to a complete stop before leaving the machine unattended.
- 12. Make a safe working environment.** Do not use machine in a damp, wet area, or where flammable or noxious fumes may exist.
- 13. Disconnect main power before service machine.** Make sure power switch is in the off position before re-connecting.
- 14. Use correct amperage extension cords.** Undersized extension cords overheat and lose power. Replace extension cords if they become damaged.
- 15. Keep machine well maintained.** Keep blades sharp and clean for best and safest performance. Follow instructions when lubricating and changing accessories.
- 16. Keep machine well guarded.** Make sure guards on machine are in place and are all working correctly.
- 17. Do not overreach.** Keep proper footing and balance at all times.
- 18. Secure workpiece.** Use clamps or a vice to hold the workpiece where practical. Keeping the workpiece secure will free up your hand to operate the machine and will protect hand from injury.
- 19. Check machine over before operating.** Check machine for damaged parts, loose bolts, Keys and wrenches left on machine and any other conditions that may effect the machines operation. Repair and replace damaged parts.
- 20. Use recommended accessories.** Refer to instruction manual or ask correct service officer when using accessories. The use of improper accessories may cause the risk of injury.
- 21. Do not force machinery.** Work at the speed and capacity at which the machine or accessory was designed.
- 22. Use correct lifting practice.** Always use the correct lifting methods when using machinery. Incorrect lifting methods can cause serious injury.
- 23. Lock mobile bases.** Make sure any mobile bases are locked before using machine.
- 24. Allergic reactions.** Certain metal shavings and cutting fluids may cause an allergic reaction in people and animals, especially when cutting as the fumes can be inhaled. Make sure you know what type of metal and cutting fluid you will be exposed to and how to avoid contamination.
- 25. Call for help.** If at any time you experience difficulties, stop the machine and call you nearest branch service department for help.



# WARNING

## Wood Lathe Safety Instructions

---

Machinery House  
requires you to read this entire Manual before using this machine.

- 1. Maintenance/Adjustments.** Make sure the lathe is turned off and disconnect from the main power supply and make sure all moving parts have come to a complete stop before any inspection, adjustment or maintenance is carried out.
- 2. Lathe Condition.** Lathe must be maintained for a proper working condition. Never operate a lathe that has damaged or worn parts. Scheduled routine maintenance should be performed on a scheduled basis.
- 3. Leaving a Lathe Unattended.** Always shut the lathe off and make sure all moving parts have come to a complete stop before leaving the lathe. An unsupervised running lathe can cause serious injury.
- 4. Avoiding Entanglement.** Remove loose clothing, belts, or jewelry items. Tie up long hair and use the correct hair nets to avoid any entanglement with moving parts.
- 5. Guards safety.** Make sure all guards supplied are in good condition and in place. Make sure the lathe sits on a flat stable surface.
- 6. Eye and Face protection.** Always wear eye protection and a face shield when operating the lathe.
- 7. Respiratory protection.** Always wear a respirator when using the machine. Wood dust may cause allergies or long term respiratory health problems.
- 8. Mounting the workpiece.** Make sure the workpiece is properly embedded on the headstock and tailstock centres. A loose workpiece can be thrown across the room and cause serious injury to you or a by-stander.
- 9. Workpiece clearance.** Rotate the workpiece by hand to check for adequate clearance before turning the lathe on.
- 10. Stopping the lathe.** Do not slow or stop the lathe chuck by using your hand against the workpiece. Allow the lathe to stop on its own.
- 11. Avoiding Entanglement.** Remove loose clothing, belts, or jewelry items. Never wear gloves while machine is in operation. Tie up long hair and use the correct hair nets to avoid any entanglement with moving parts.
- 12. Workpiece condition.** Always inspect the workpiece condition. Check for knots, splits, nails, and any other potentially dangerous conditions. Make sure joints of glued-up pieces have high quality bonds and won't fly apart during operation.
- 13. Adjusting tool rest height.** Always adjust the tool rest to the correct height to provide proper support for the turning tool you will be using. Test the clearance between the tool rest and the workpiece by rotating the workpiece by hand before turning the lathe on.
- 14. Speed selection.** Select the appropriate speed for the type of work, material, and tool bit. Allow the lathe to reach full speed before using.
- 15. Use sharp Chisels.** Keep lathe chisels properly sharpened and held firmly in position when using.
- 16. Faceplate Turning.** When faceplate turning, use lathe chisels on the downward spinning side of the workpiece only.
- 17. Sanding/Polishing.** Remove the tool rest when performing sanding or polishing operations on the rotating spindle.
- 18. Material removal rate.** Removing too much material at once may cause the workpiece to fly out of the lathe.
- 19. Workpiece Vibration.** If the workpiece vibrates, turn off the machine immediately. Check to make sure the workpiece is centered and balanced. Trim excess waste off the corners with a bandsaw or table saw to reduce vibration. Make sure the workpiece is securely attached in setup.
- 20. Power outage.** In the event of a power failure during use of the lathe, turn off all switches to avoid possible sudden start up once power is restored.
- 21. Clean work area.** Keep the area around the lathe clean from oil, tools and chips.
- 22. Call for help.** If at any time you experience difficulties, stop the machine and call your nearest branch service department for help.

# PLANT SAFETY PROGRAM

## **NEW MACHINERY HAZARD IDENTIFICATION, ASSESSMENT & CONTROL**

### **Wood Lathe**

Developed in Co-operation Between A.W.I.S.A and Australia Chamber of Manufactures  
 This program is based upon the Safe Work Australia, Code of Practice - Managing Risks of Plant in the Workplace ( WHSA 2011 No10 )

Item No.	Hazard Identification	Hazard Assessment	Risk Control Strategies <small>(Recommended for Purchase / Buyer / User)</small>
A	ENTANGLEMENT	HIGH	Eliminate, avoid loose clothing / Long hair etc.
C	CUTTING, STABBING, PUNCTURING	MEDIUM	Isolate power to machine prior to any checks or maintenance. Do not open or clean inside until the machine has completely stopped.
D	SHEARING	MEDIUM	Make sure all guards are secured shut when machine is on.
F	STRIKING	MEDIUM	Ensure workpiece is secured and toolrests are locked tight in correct position. A face mask must be worn at all times. Secure and support heavy material.
H	ELECTRICAL	MEDIUM	Remove all loose objects around moving parts. Ensure spindle is in the correct direction before machining.
O	OTHER HAZARDS, NOISE, DUST.	LOW	All electrical enclosures should only be opened with a tool that is not to be kept with the machine.  Wear hearing protection as required. Must be connected to dust extraction

Plant Safety Program to be read in conjunction with manufactures instructions



[www.machineryhouse.com.au](http://www.machineryhouse.com.au)



[www.machineryhouse.co.nz](http://www.machineryhouse.co.nz)

Authorised and signed by:  
 Safety officer:

  
 Manager:

Revised Date: 12th March 2012